

**6010M, 6011M, 6012M, 6013M and 6091M Series Oil-Tight Non-Relampable Neon-LED Indicator Lights**

**DESCRIPTION AND FEATURES**

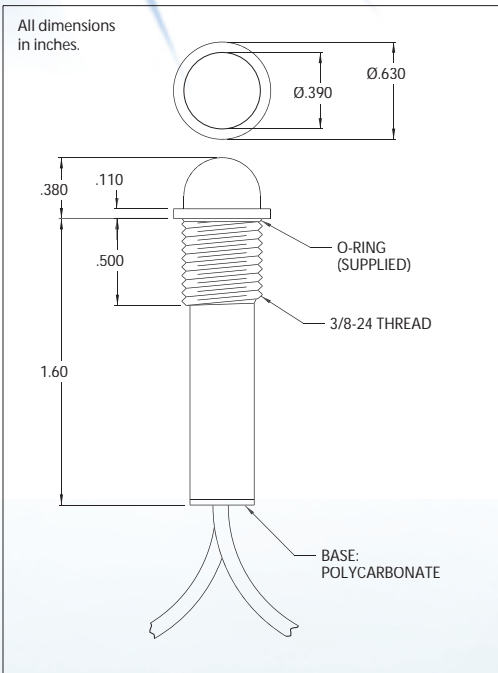

Solid-state indicator lights complete with built-in current-limiting resistor and rectifier diode.

Mounting: Ø.380(9.65) hole. Supplied with internal tooth lock washer and hex nut. Mounting hole pattern on page SP2.

Wire Leads: No.22\* AWG (105°C), 4.40/4.80 long, stripped .430/.570

Lens: Polycarbonate

Bezel: Polished stainless steel. For black finish add "X" after the series letter(s).

Gaskets: Buna-N

Housing: Black Nylon

Lens Color	Neon	
	Model No. (105-125VAC)	Model No. (208-250VAC)
Red	6010M1	6011M1
Amber	6010M3	6011M3
Green	6012M5*	6013M5*
Lamp used	C2A+Resistor	C2A+Resistor
Lamp Color	Black	1 Black/1 Red

Lens Color	LED Solid State Indicator		
	Model No. for 12V	Model No. for 24V	Incorporates LED
Red	6091M1-12V	6091M1-24V	4304H1
Green	6091M5-12V	6091M5-24V	4304H5
Yellow	6091M7-12V	6091M7-24V	4304H7
Internal Resistor (ohms)	390	1000	-

\* Incorporates G2B lamp and resistor. Underwriters Laboratories (UL) File No. E20325 Canadian Standards Association (CSA) File No. LR13346

Note: Also incorporates IN4004 (400 P.I.V.) rectifier diode. Red lead positive.